

## 300 PSI CWP Iron Body Gate Valves

Fire Protection Post Indicator Valve • Bolted Bonnet • Indicator Post Pattern • Non-Rising Stem • Resilient Wedge • Epoxy Coated Interior/Exterior



### 300 PSI/20.6 Bar Non-Shock Cold Working Pressure

UL/ULC LISTED • FM APPROVED • CERTIFIED LEAD-FREE BY TRUESDAIL LABORATORIES TO NSF/ANSI/CAN 61 & 372

#### MATERIAL LIST

PART	SPECIFICATION
1	Valve Body Ductile Iron ASTM A536
2	Resilient Wedge Ductile Iron ASTM A536 / EPDM ASTM D2000
3	Wedge Nut ASTM B584 UNS C83600
4	Stem Stainless Steel 304
5	Bonnet Gasket EPDM ASTM D2000
6	Bonnet Screw Corrosion-resistant Steel
7	Bonnet Ductile Iron ASTM A536
8	Stem Primary O-Ring EPDM ASTM D2000
9	Stem Thrust Washer (lower) Bronze ASTM B584 UNS C83600
10	Stem Thrust Washer (upper) Stainless Steel ASTM A276 UNS S41000
11	Gland Seal O-Ring EPDM ASTM D2000
12	Stem Seal Bushing ASTM B584 UNS C83600
13	Stem Secondary O-Ring EPDM ASTM D2000
14	Gland Flange Ductile Iron ASTM A536
15	Stem Ring Wiper EPDM ASTM D2000
16	Square Operating Nut Cast Iron ASTM A126-B
17	Operating Nut Washer ASTM A276 SS304
18	Operating Nut Screw Alloy Steel ASTM A574M Zinc Plated
19	Gland Flange Screw Alloy Steel ASTM A574M Zinc Plated
20	Indicator Flange Screw Alloy Steel ASTM A574M Zinc Plated
21	Indicator Post Flange Cast Iron ASTM A126-B
22	UL/FM Label (not shown) Aluminum
23	Drive Screw, Label (not shown) Stainless Steel 304



**F-609-RWS**  
Flanged



**M-609-RWS**  
Mechanical

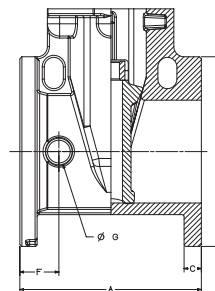

**F-609-RWS**  
Flg x Flg

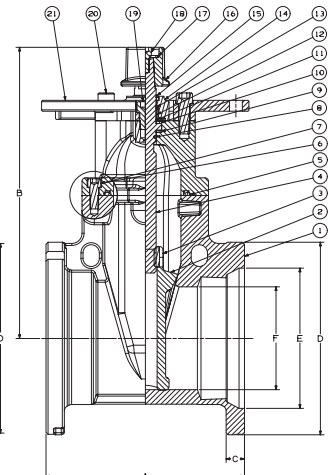

**M-609-RWS**  
MJ x MJ

Coating — Electrostatically applied fusion-bonded epoxy 8-20 mil. inside and outside meets or exceeds AWWA C550.

NOTE: Flanged valve is consistent with ANSI B16.1 Class 125.

### DIMENSIONS—WEIGHTS—QUANTITIES

Size	M-609-RWS Dimensions						Bolt				Weight	
	A	B	C	D	E	F	Circle	Flange	Turns			
In. mm.	In. mm.	In. mm.	In. mm.	In. mm.	In. mm.	In. mm.	In. mm.	In. mm.	Holes	To Open	Lbs.	Kg.
4	100	10.0 254	13.4 340	1.00 25	9.1 232	6.02 153	3.98 100	7.50 191	4	12.5	72	33
6	150	11.5 292	16.9 429	1.06 27	11.1 283	8.12 206	5.96 150	9.50 241	6	15.0	101	46
8	200	11.5 292	20.6 523	1.13 29	13.4 340	10.27 261	7.91 200	11.75 298	6	16.7	148	67
10	250	13.0 330	23.7 602	1.19 30	15.6 397	12.34 313	9.90 250	14.00 356	8	20.8	236	107
12	300	14.0 356	27.1 688	1.25 32	18.0 456	14.44 367	11.81 300	16.25 413	8	25.0	353	160

Size	F-609-RWS Dimensions						Bolt				Weight	
	A	B	C	D	F	G	Circle	Flange	Turns			
In. mm.	In. mm.	In. mm.	In. mm.	In. mm.	In. mm.	In. mm.	In. mm.	In. mm.	Holes	To Open	Lbs.	Kg.
4	100	9.0 229	13.4 340	0.94 23.9	9.0 229	2.13 54	1.4 36	7.50 191	8	12.5	75	34
6	150	10.5 267	16.9 429	1.00 25.4	11.0 279	2.26 57	1.5 39	9.50 241	8	15.0	106	48
8	200	11.5 292	20.6 523	1.13 28.7	13.5 343	2.46 62	1.5 39	11.75 298	8	16.7	163	74
10	250	13.0 330	23.7 602	1.19 30.2	16.0 406	3.15 80	1.8 46	14.25 362	12	20.8	256	116
12	300	14.0 356	27.1 688	1.25 31.8	19.0 483	2.91 74	1.8 46	17.00 432	12	25.0	394	181
14	350	15.0 381	31.7 805	1.38 35.0	21.0 533	2.95 75	3.2 80	18.75 476	12	43.8	625	284
16	400	16.0 406	34.1 866	1.50 38.0	23.5 597	3.07 78	3.2 80	21.25 540	16	50.0	825	375

**FREEZING WEATHER PRECAUTION:** Subsequent to testing a piping system, gate valve should be in an open position to allow complete drainage.



**WARNING:** This product can expose you to chemicals including lead, which is known to the State of California to cause cancer and birth defects or other reproductive harm. For more information go to [www.P65Warnings.ca.gov](http://www.P65Warnings.ca.gov).

LEAD-FREE: Weighted average lead content <0.25%

Visit our website for the most current information.